

TECHNICAL DATA

Diamond Gas Table Low is made of stainless steel frame. There is a gas burner and gas tap. The burner is atmospheric and supplied by a mixture of liquid gas and air or natural gas and air. The Main Burner ignition carried by Pilot Burner. The Main Burner equipped by Safety Thermocouple.

- **Data Table**

Table 1: Technical Specification

Technical Specification			
Model	NGTL 6 – 65 (SO)		
Overall Dimension (mm)	Width	Depth	Height
	600	650	360 / 467
Gas Connection (G)	R. $\frac{3}{4}$ "		
Total Nominal Thermal Power	28 kW 24000 kCal/h		
Gas Pressure	Gas G30 / G31 = 28 / 37 mbar		
Ignition	Manual		

Manual Instructions for Gas Table Low

- Overall Dimension

NGTL 6-65 (SO)

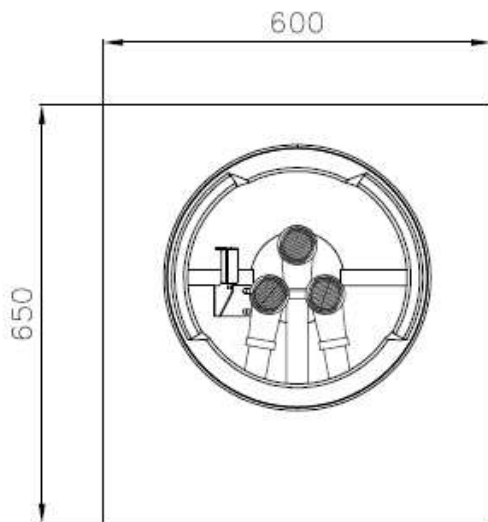
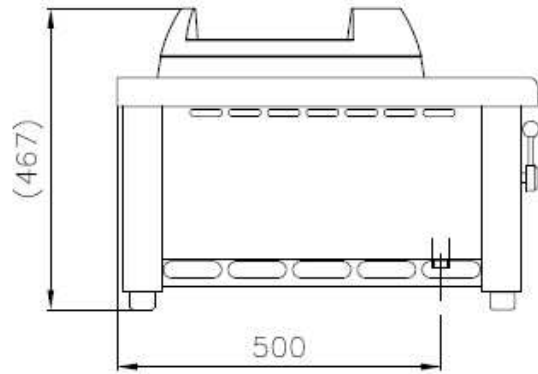
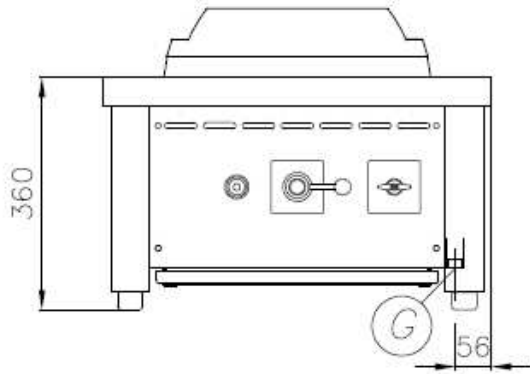

ⓐ Gas Connection R 3/4"

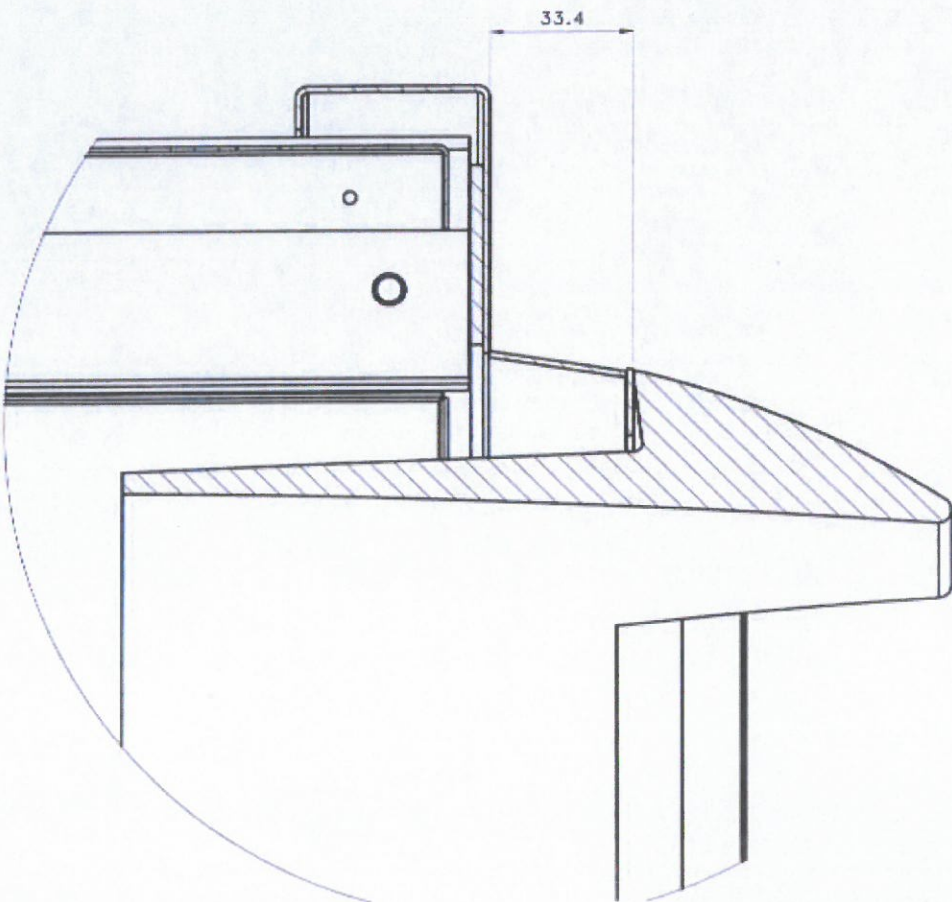
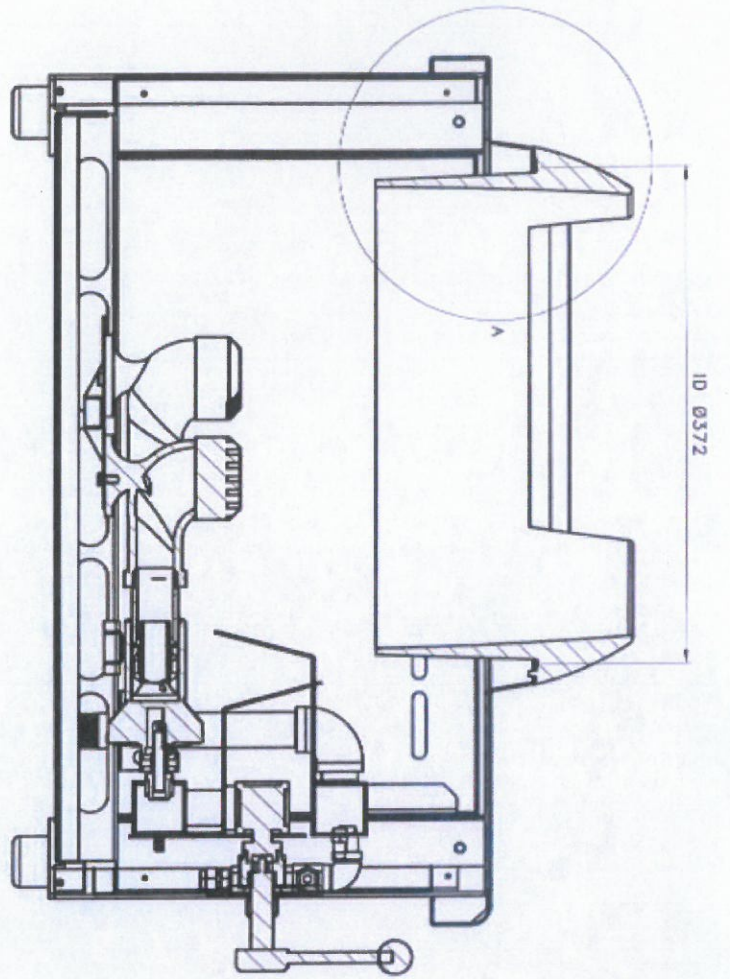

DETAIL A
SCALE 2:2.5