

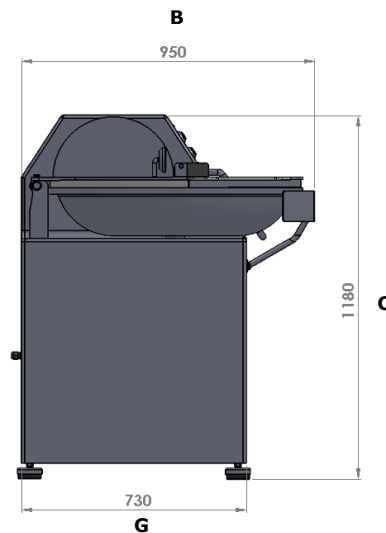

# Cutter VILLA C50

# Bowl Chopper VILLA C50

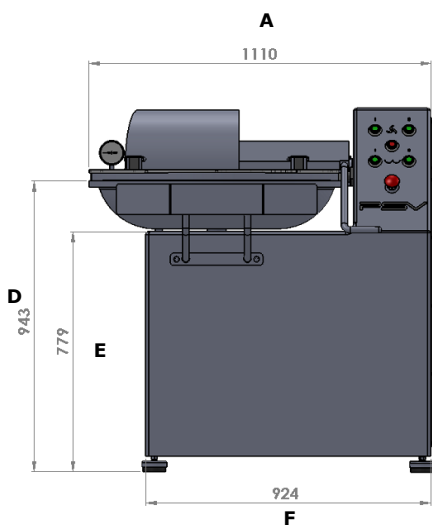

Dimensions (mm)	
A	1110
B	950
C	1180
D	943
E	779
F	924
G	730

# VILLA C50 – CUTTER 50 LITRES

## VILLA C50 – 50 LITERS BOWL CHOPPER

### SUR SOCLE

- Deux moteurs distincts
- Deux vitesses de travail indépendantes pour les couteaux et la cuve
- Frein sur arbre moteur
- Nettoyage simple et rapide grâce au design soigné de cette machine
- Machine totalement sécurisée
- Couvercle antibruit
- Conseil d'entretien : Vérifier régulièrement l'affûtage des couteaux

### DOTATION DE SERIE

- Tête 3 couteaux

### OPTIONS

- Tête 6 couteaux
- Thermomètre



### FLOOR STANDING

- Two distinct motors
- Two independent working speeds for both knives and bowl
- Breaking system on engine shaft
- Simple and fast cleaning thanks to this machine's efficient design
- Fully safe machine
- Anti-noise lid
- Maintenance tip : Check regularly for knives proper sharpness

### STANDARD SET UP

- Three knives head

### OPTIONS

- Six knives head
- Thermometer



**Ampérage maximum : 60A**

**Maximum Amperage : 60A**

Modèle	Encombrement (mm)	Colisage (mm)	Poids (kg)	Capacité (l)	Puissance Moteur de cuve et de bras	Vitesse de rotation bras et cuve (RPM)	Tension	Quantité de mélange maximale (kg)
Model	Size (mm)	Packing details (mm)	Weight (kg)	Capacity (l)	Bowl motor & knives motor power	Rotation speed (RPM)	Voltage	Maximum Mix quantity (kg)
C50	1110x950x1180	1400x1200x1550	485	50	Cuve / Bowl : 0.45Kw / 0.9kW Couteaux / Knives : 6Kw / 7.5kW	Cuve / Bowl : 12-24 Couteaux / Knives : 1500-3000	3/380V	35