

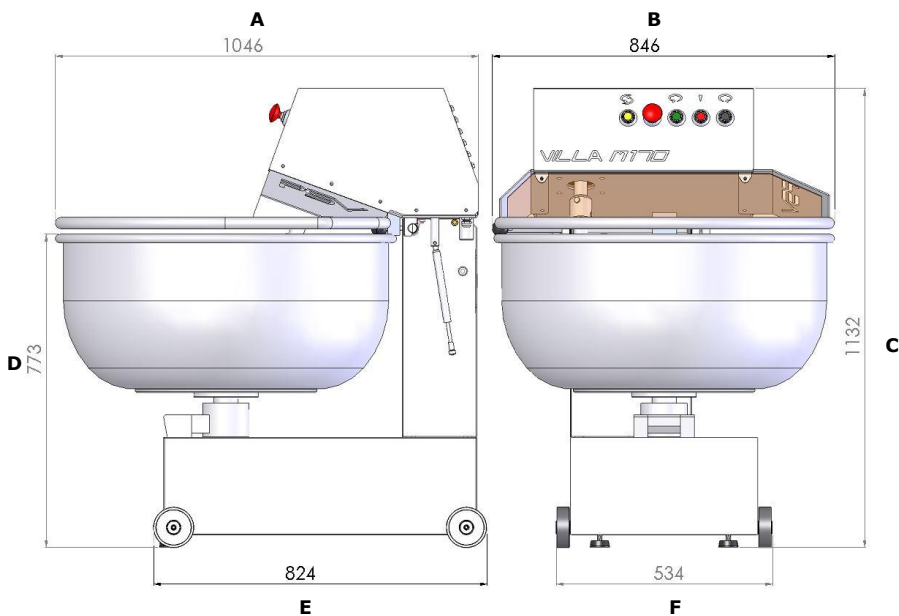

**Mélangeur
VILLA M170**

**Meat Mixer
VILLA M170**



Dimensions (mm)	
A	1046
B	846
C	1132
D	773
E	824
F	534

VILLA M170 – MELANGEUR A VIANDE 170 LITRES

VILLA M170 – MEAT MIXER 170 LITERS

SUR SOCLE

Entièrement en acier inoxydable

Cuve motorisée et basculante

Quatre roulettes

Deux moteurs : Cuve et bras

Machine totalement sécurisée

OPTIONS

Bras démontable

Deux roues directrices à frein à l'avant

FLOOR STANDING

Full stainless steel

Motorized and tiltable bowl

Four wheels

Two motors : bowl and arm

Machine fully secure

OPTIONS

Removable arm

Two front wheels drivable with brakes



Modèle	Encombrement (mm)	Colisage (mm)	Poids (kg)	Capacité (litres)	Dimensions de la Cuve (mm)	Puissance Moteur de bras et cuve	Vitesse de rotation bras et cuve (RPM)	Tension	Quantité de mélange mini et maxi (kg)
<i>Model</i>	<i>Size (mm)</i>	<i>Packing details (mm)</i>	<i>Weight (kgt)</i>	<i>Capacity (liters)</i>	<i>Bowl size (mm)</i>	<i>Power</i>	<i>Rotation speed (RPM)</i>	<i>Voltage</i>	<i>Mix quantity mini and maxi (kg)</i>
M170	1046x846x1132	1115x1200x1370	220	170	800x380	Bras/Arm : 1.1 kW Cuve/Bowl : 0.75 kW	Bras/Arm : 47 Cuve/Bowl : 9	3/380V	Mini : 15 Maxi : 90