

Il Carrettino Classic



Ventilated refrigeration ice-cream cart. Operator side closure with flap. The cabinet can contain a double level of trays H120 in the display basin.



REFRIGERANT
R290



LIGHTING
Led



INSTALLATION
Plug-in



TEMPERATURE (°C)
-16/-14



DEFROST
Automatic



CLIMATIC CLASS
4







STANDARD EQUIPMENT

Scoop washer
Tap
Cans
Electronic command panel
Internal LED basin lighting
Stainless steel serving surface
Wheels

OPTIONAL

Stainless steel tray 5 litres - 360 x 165 x 120H
Stainless steel tray 4.75 litres - 260 x 165 x 170H
4.75 litre tray spacer kit

AVAILABLE COLOURS

Yellow Graphic 	Brown Graphic 	White Graphic 	Black Graphic 
---	--	--	--

TRAY CAPACITY

Display basin			
5 litres (stackable in a double row)	360 x 165 x 120H	6 + (6)	
4.75 litres	260 x 157 x 170H	10	

MODEL

MODEL			CLASSIC
External dimensions	L x P x H	mm	RV 2000 x 1285 x 2081
Refrigerant			R290
Refrigeration			Ventilated
Capacity	Gross - Net	lt	260 - 104
Product temperature		°C	-16 / -14
Defrost			Hot Gas
Climatic class		No.	4
Environmental conditions		°C/%RH	30 / 55
Compressor	Type - No.		Hermetic - 1
Power supply		V/ph/Hz	230 / 1 / 50
Electrical input	Standard	W/A	590 / 2.8
	Defrost	W/A	660 / 3.1
Net weight		kg	205

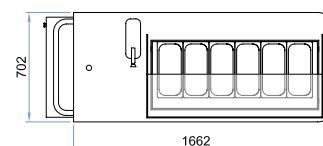
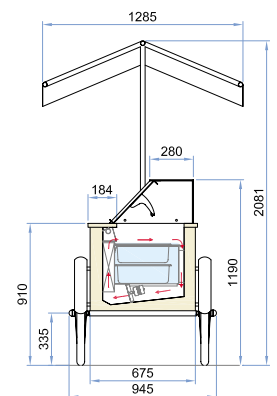
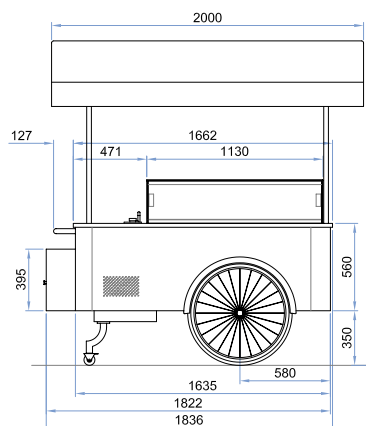

DISPLAY BASIN
DOUBLE LEVEL
TRAYS H120